

Rally Mongolia 2018 REGULATIONS



FACoat INTERNATIONAL CROSS COUNTRY RALLY

RALLY MONGOLIA 2018

CONTENTS

- ART.1 DEFINITION OF THE EVENT
- ART.2 RULES
- ART.3 COMPETITOR
- ART.4 GENERAL PROVISIONS FOR VEHICLES
- ART.5 ELIGIBLE CATEGORIES OF MACHINES
- ART.6 ENTRIES
- ART.7 TECHNICAL AND ADMINISTRATIVE INSPECTIONS
- ART.8 IDENTIFICATION DISPLAYSPACE
- ART.9 ROUTE BOOK, TRAFFIC REGULATIONS
- ART.10 ASSISTANCE
- ART.11 MEDICAL SYSTEM
- ART.12 CHECK CARD
- ART.13 CONTROL ZONE
- ART.14 TIME CONTROL
- ART.15 PASSAGE CONTROL
- ART.16 ETAP(SPECIAL and LIAISON)
- ART.17 BRIEFING
- ART.18 REGROUPING
- ART.19 START
- ART.20 PLACINGS
- ART.21 PROTESTS
- ART.22 SAFETY
- ART.23 RESPONSIBILITY FOR HELPING OTHERS
- ART.24 PICTURE COVERAGE
- ART.25 RESOLUTION OF CONFLICTS
- ART.26 ENVIRONMENT
- ART.27 PENALTIES
- Control Flag Information
- TECHNICAL REGULATIONS AUTOMOBILE
- TECHNICAL REGULATIONS MOTORCYCLE

ART. 1 DEFINITION OF THE EVENT

1.1 PREAMBLE

RALLY MONGOLIA 2018 is an international cross country rally spanning 4000 kilometers and taking place over an 8 day period from August 12 to August 19, 2018. It is held every year under the sponsorship of the SSER Organization. All sections of the rally take place in the country of Mongolia. A rough idea of the distances covered is announced as general information but the route details are kept a complete secret.

1.2 SPIRIT OF THE EVENT

All participants should have a strong independent spirit. As well, participants shall be required to acknowledge the risk of this Rally and have the will and sportsmanship to overcome any difficulties encountered in Mongolia's beautiful but severe environment. It is our intention, through this event, to carry out a goodwill mission for international peace, those who live in Mongolia should be held in the utmost of respect. To make the most of Mongolia's great natural beauty and to preserve its treasures, investigation and planning of the route, trial run, and all other things concerned with this event are being carefully planned, accompanied by the Mongolia Nature and Environment Agency officers. Participants and all concerned must pay attention to the wishes of the organizer and make sincere efforts to preserve the environment of this country.

1.3 OFFICIAL NOTICE

1.3.1 OFFICIAL NAME OF THE EVENT

FA-coat RALLY MONGOLIA 2018 INTERNATIONAL CROSS COUNTRY RALLY

1.3.2 ORGANIZERS

SSER ORGANISATION : Chairman YAMADA Tetsu
1992-4 Minamikata, Toon, Ehime, 791-0301 Japan
Tel +81-89-960-6905 / FAX +81-89-960-6906
E-mail: support@sser.org

1.4 OFFICE

SSER ORGANISATION

1992-4 Minamikata, Toon, Ehime, 791-0301 Japan
Tel +81-89-960-6905 / Fax +81-89-960-6906 E-Mail: support@sser.org

TOKYO OFFICE

JAPAN RACING MANAGEMENT

2-29-6, Ebisu, Shibuya-ku, Tokyo, 150-0013 Japan
Tel +81-3-3440-5581 / Fax +81-3-3440-5583 E-Mail: teru@j-r-m.co.jp

MONGOLIA MONGOLIA AUTO MOTO FEDERATION

CORRESPONDENT

NORTH AMERICAN
Lawrence Hacking
<http://overlandadventurerally.com/>
lawrencehacking@gmail.com

EUROPEAN
Team Kaiser Thorsten Kaiser
<http://team-kaiser.de/>
teamkaiser@gmx.de or Karl.dersch@web.de

MONGOLIA
Natsag Munkh-Amgalan
munkhamgalann@yahoo.com

BEIJING
PAUL B.Y.SHI
<http://www.chinaoverlandinfo.com>
paulbys@chinaoverlandinfo.com

1.5 ABOUT THE TRANSPORTATION

Regarding FA-coat Rally Mongolia 2018, SSER is announcing the official partner (consignee) and customs clearance agent/(customs broker) in charge of receiving operation within Mongolia as below.

At the present time in Mongolia, the customs clearance is getting very strict. The relevant authorities require the usage ATA Carnet for customs clearance. This is a temporary custom clearance notebook on the condition of re-exportation. Please confirm export-import agents in your own country.

Please write following Mongolian federation name as a consignee/recipient in the shipping documents, NOT sender's name. In case when you write your name as a consignee/recipient, your shipping customs clearance acceptance will NOT start until you go to accept your shipments. Therefore, you could have trouble with customs clearance and procedures. Please designate the conveyance as below to keep consistency of business procedures.

[Mongolian Consignee]

MONGOLIAN AUTOMOBILE MOTORCYCLE FEDERATION MR. D.Ochirsukh

Mongolia Ulaanbaatar Khanuul Duureg Chinggis Avenue Olimpic House 1F. #118 zip code 14210

TEL +976-99909473

[Mongolian Shipping Company]

TUUSHIN CO.,LTD. SALES DEPARTMENT MR.L.BAYARSAIKHAN

Prime Minister Amar's Str.2, Ulaanbaatar 210620. Mongolia

TEL +976-11-320064,312092/322800,325510 E-mail: bayaraa@tuushin.mn

1.6 SCHEDULE

Closing date for Pre-entry CASE 1	Dec.25,2017
Closing date for Pre-entry CASE 2	Feb. 26,2018
Closing date for Pre-entry CASE 3	Apr. 25,2018
Closing of Final entries	Jul. 1, 2018
scrutineering day 1 participant from abroad	Aug. 10, 2018 13:00~
scrutineering day 2	Aug. 11, 2018 10:00~
Comprehensive briefing in Ulaanbaatar	Aug. 11, 2018 17:00~
ETAP-1 400km ULAANBAATAR 8:00 Start	Aug. 12, 2018
ETAP-2 560km	Aug. 13, 2018
ETAP-3 500km	Aug. 14, 2018
ETAP-4 560km	Aug. 15, 2018
ETAP-5 500km	Aug. 16, 2018
ETAP-6 450km	Aug. 17, 2018
ETAP-7 450km	Aug. 18, 2018
ETAP-8 380km ULAANBAATAR(H) Goal	Aug. 19, 2018
Awards ceremony closing ceremony	Aug. 20, 2018 17:00~

*The cruising distance is 280km

ART.2 RULES

This rally shall observe every rule concerning the each international federation (FIA,FIM)Cross Country Rally and follow the rules which SSER ORGANISATION has produced exclusively for this rally.

ART.3 COMPETITORS

3.1 CONDITIONS FOR ENTRY

A. A competitor should be, regardless of nationality and sex, *older than 18 and have an International Driving License which is valid for driving the entrant's vehicle until August 31st, 2018. (FIA or FIM international competitor's license is not necessary.)*

B. The organizer shall have the right to refuse the entry to any competitor without specifying a reason.

C. Any competitor who is replaced by another competitor shall be disqualified. Similarly an entrant's vehicle must be driven only by the competitor who has been registered it in his/her name, and must not be driven by any other person even if the vehicle needs to be moved.

If a competitor accepts the above assistance from any other person than the rally official, he/she shall be disqualified.

Exceptional case: Registered mechanics can drive in bivouac before check cards are not issued for them.

D. All the competitors should consider all the danger happening in this rally before entry. All the participants and people concerned should accept that the organizer shall not be legally responsible for the bodily or mental harm or the damage to machines and personal belongings.

3.2 COMPETITORS AND PARTICIPANTS

Participant is a general term including competitors, press-persons, team staffs, mechanics and sponsors. The term competitor is limited to a person who has a number card/cloth and participates in the race.

3.3 PRIZES FOR RIDERS(Motorcycles class only)

Prizes for these Classes shall be awarded regardless of the Prizes for Individual Total, for each Class or each Category.

LADIES CLASS: awarded to all the female riders.

MANUFACTURER CLASS: KTM, YAMAHA, HONDA, Husqvarna, OTHERS

3.4 PRIZES FOR DRIVERS(Auto, Camion class only)

Prizes for these Classes shall be awarded regardless of the Prizes for Individual Total, for each Class or each Category.

LADIES CLASS: awarded to all the female drivers. (Eligible only for females registered as drivers, not as co-drivers.)

3.5 TEAM-CLASS

In addition to these above prizes, another prize over all classes will be awarded to the registered team that has shown the best performances in the rally.

ART.4 GENERAL PROVISIONS FOR VEHICLES

4.1 NOTES

An entrant vehicle should not be modified in any other way than described by the vehicle regulations of FIA or FIM respectively. Only vehicles that are equipped with the items specified in the article of Safety Equipment shall be allowed to enter.

4.2 DATE OF MANUFACTURE AND REGISTRATION

An entrant vehicle should be manufactured in the country of production by MAY 25, 2018.

An entrant vehicle, with the exception of the cases specified in the item 4.3, should be officially registered the administration of the participant's country in the name of the participant/competitor. Therefore, each crew in Auto Camion Class must include one person who has registered the vehicle in his/her name.

Those who wish to entry the rally with an unregistered vehicle should possess all necessary authority over the vehicle.

4.3 EXCEPTIONS OF VEHICLE OWNERSHIP

One exception to the above rule 4.2 is *when a crew or a competitor is the press or in the similar position and rents his/her vehicle from a manufacturer or an import trader with a definite purpose. In this case, each representative should submit permission of the owner to use the vehicle.* Those who satisfy these conditions shall be regarded as exceptions to the rules specified in the item 4.2.

4.4 EXPORT/IMPORT OBLIGATION FOR VEHICLES AND EQUIPMENT

All the vehicles and equipments that are temporarily imported to Mongolia for the rally should be brought back from Mongol. It is prohibited to abandon, dispose or transfer articles except for the following:

A) Destruction by fire

B) Articles lost in places (for example in a valley or in sand where it would be unable to be practically retrieved)

C) An unavoidable accident such as robbery

All above must be proved by the responsibility of the participant by the police of Mongolia.

The above vehicles or equipment abandoned by participants shall not be searched for or recovered by the organizer. If the participants will not prove it, they have to pay all costs of the board customs.

4.5 FUEL AND ENGINE OIL

The participant prepares for fuel and engine oil as a general rule at service stations during a trip. In the difficult area, an organizer prepares and performs the information beforehand. Both the gasoline and the diesel to be provided are produced in Russia. The organizer shall not be held responsible for the fuel quality to be secured by the organizer as much as possible.

4.6 REFUELING POINTS AND MAXIMUM DISTANCE OF CRUISING

When there is not a service station, in the vicinity of an everyday goal point (of a bivouac), a tanker is prepared for refueling.

4.6.1

The maximum cruise ranges of all participation vehicle must be more than 280km+10%.

A competitor is responsible unable to continue the race due to gas shortage.

4.7 PRESERVATION OF THE ENVIRONMENT

During the rally, sponsors and participants must never and under any circumstances throw away trash. Trash from your lunch-pack must be brought back to the bivouac and later exchanged for the next day's lunch-pack. **Your race number is attached to the water pet bottles we distribute so those who carelessly throw them away somewhere will have to pay a fixed penalty.** Waste oil from oil changes and similar items should be disposed of at the recycle oil drum at the rally headquarters. Those who do not observe these important rules will be disqualified. No exceptions or protests will be accepted.

ART.5 ELIGIBLE CATEGORIES OF MACHINES

5.1 MOTORCYCLE CLASS

5.1.1

The entrant motorcycles shall be classified into the following groups:

Group1 PRODUCTION (retails, unmodified)	Group1-1	0 - 250cc
	Group1-2	251 - 450cc
	Group1-3	451cc and over
Group2 SUPER PRODUCTION (retails, modified)	Group2-1	0 - 250cc
	Group2-2	251 - 450cc
	Group2-3	451cc and over
Group3 EXPERIMENTAL	Group3-1	Quad
	Group3-2	Side-cars

5.2 AUTO CAMION CLASS

5.2.1

The entrant auto camions shall be classified into the following three classes:

- I : PRODUCTION CLASS vehicles conform to FIA group T1 and group T2
- II : NATIONAL CLASS vehicles do not conform to the rules specified by FIA
- III : CAMION CLASS vehicles conform to FIA group T4

5.2.2

This rally shall be divided into the following two categories by the type of engine:

- Category I : gasoline
- Category II : diesel

5.2.3

The technical regulations for modification of vehicles shall conform to the rules specified by FIA/FIM.

ART. 6 ENTRIES

6.1 ENTRY

The entry applicant has to submit the official Entry Form and the necessary papers by July 1, 2018.

6.2 ENTRY FEES

Each person must pay this entry fee regardless of his/her form of participation.

6.2.1 PERSONAL FEE

For all forms of participation, there is a participation fee for each person. Depending on when the entry procedure is completed, the entry fee is divided into 3 cases, Case 1 through Case 3. The entry fee is paid in two installments: the pre-entry fee and the final entry fee.

One person is accompanied	CASE 1	CASE 2	CASE 3
until Dec.25,2017	1,000usd	-	-
Until Feb.26,2018	-	1,500usd	-
Until Apr.25,2018	-	-	2,500usd
Until Jul.1, 2018	2,800usd	2,800usd	2,800usd
TOTAL	3,800usd	4,300usd	5,300usd

The entry fee for team managers, mechanics, press, and others related to the competition is a personal fee of 200,000JPY. Transportation is by automobile. Plan on 7 hours of travel per day. Helicopter seats may be reserved. However, there are a limited number of seats and reservations will be first come, first served. Additional fee for helicopter seat 400,000JPY; 2 hours of travel per day. A support car can also be registered. 4WD automobiles will be available in Mongolia (with driver and gasoline included) for a fee of 180,000JPY. Up to 2 mechanics can ride in one car. If an interpreter is necessary, there will be a separate fee for that.

6.2.2 Entry Fees in item includes the following:

- Race registration fee
- In-race catering and water supply
- Competition during the bivouac (from August 12, 2018 to August 19, 2018)
- Safety control during race
- Medical support
- Application procedures for Mongolian driver's license, etc.
- Mongolian vehicle registration fee
- Personal assistance service prepared by promoters
- Participation fee for awards ceremony etc., others

6.2.3 Entry Fees in item does not include:

- Airfare from your country to Ulaanbaatar and from Ulaanbaatar to your country
- Transport and customs fees from your country to Mongolia for your participating vehicle
- Visa fees
- Costs after retiring
- Overseas travel insurance
- Fuel supply at gasoline stations
- Non-competition period of stay
- Non-competition meal period

6.3 ENTRY AND ITS FEES

Each person entering must complete the pre-entry procedure. The entry fee, consisting of the total entry fee minus the pre-entry fee for those who paid a pre-entry fee or the entire entry fee for those who did not, must be deposited into the bank account below by July 1, 2018.

Bank account:	Bank name	Iyo Bank
	Branch	Ishii Branch
	Bank account No.	1361783
	Folder name	SSER Organisation
	SWIFT code	IYOBJPJT

Address of Ishii Branch of Iyo Bank:
 5-1-31, Asoda, Matsuyama, Ehime, Japan
 TEL: +81-89-941-1191

6.4 REJECTION AND CANCELLATION OF ENTRY

Request for Cancellation and refund of Pre Entry and Final Entry should be sent only by authorized mail in order to avoid any argument:

- 30% of payment shall be returned when cancellation is made before noon of June 30, 2018 of Japan Time,
- No cancellation will be accepted after July 1, 2018.

The organizer will not refund any Entry fees to participants whose vehicles fail the technical and administrative inspections (Aug 10, 2018) due to lack of necessary documents or failure to meet technical standards/rules.

6.5 CHANGE OF COMPETITORS AND VEHICLES

A) Any change of registered competitors, either drivers or riders, after the formal entry shall not be permitted without sufficient reasons such as a sudden sickness or accident. In such a case, a participant shall report to the judges for their permission to change a competitor.

B) Any change of registered vehicles shall also not be permitted after the formal entry without sufficient reasons, such as a sudden breakdown or damage caused by an accident. In such a case, a participant shall report to the judges for their permission to change a vehicle, as well as to the organizer for the details of customs clearance.

ART.7 TECHNICAL AND ADMINISTRATIVE INSPECTIONS

7.1 ADMINISTRATIVE INSPECTIONS

Technical and Administrative Inspections will be conducted in Ulaanbaatar on August 10, 2018. All participants will receive an official letter to designate the time and the place for Inspections of August 10. Participants who are late for this time will be penalized. During administrative inspections, all participants will have an exam on knowledge of navigation and first aid.

A) All participants shall present themselves at the appointed place to attend Administrative Inspections held prior to the rally (either the inspection held in Japan or the one in Ulaanbaatar).

B) At the inspections, all participants shall present the following documents together with the documents described in Article 7.3:

- (1) Official Notice (Participation permit issued by the organizers)
- (2) Passport valid until February 28, 2019
- (3) International Driving License (valid until August 31, 2018)
- (4) Certificate of vaccination for tetanus
- (5) Certification of the participant's blood type
- (6) Visas for Mongolia

7.2 TECHNICAL INSPECTIONS

Besides the above-mentioned Administrative Inspections, Official Technical inspections will be conducted in Ulaanbaatar on August 10 to examine the technical conditions of the registered vehicles. By the time of these inspections, all of the registered vehicles should be well prepared for the actual rally.

Technical inspections include inspections for vehicles and equipment, and competitor's clothing for Motorcycle Class. Also, all competitors must present their helmets for the inspections.

Violation of the technical requirements of the rally will result in disqualification from the rally. The entry cost is not refundable in this case.

If a violation is found during the rally or when the rally is finished in Ulaanbaatar, the competitor may be judged after inspections by the inspection committee.

7.3 RESPONSIBILITIES TO ADMINISTRATION

All participants must submit the following items which are necessary for administrative inspections by the deadline of the Entry without delay.

- A) Healthcare report, written Pledge ····· 1 each
- B) Passport (valid at least until February 28, 2019) ····· 1 copy
- C) Domestic Driving License for a registered vehicle ····· 1 copy
- D) International Driving License (valid until August 31, 2018) ····· original
- E) Certificate of vaccination against tetanus ····· 1 copy
- F) Blood type certification ····· 1 copy

*Carnet and International Number plate are not needed.

7.4 REGULATIONS FOR CLOTHING AND EQUIPMENT

A) The wearing of FIA (for Auto) or FIM (for Moto) homologated helmet is compulsory throughout the race. The helmet, less than 5 years old, in good condition, must be presented in the inspections with vehicles.

The helmet should have competitor's name and blood type in English.

Motorcycles class must be obliged to wear full face helmet.

B) For Motorcycle Class, a pat thick enough to protect the spine, and a pat for each part of the shoulder, the clavicle, the chest and the abdomen is compulsory. Must be made by resin or hard materials. A waist belt will do for the abdomen. For Auto Camion Class, these are not compulsory.

C) Each participant is obliged to wear a helmet remover. The organizer does not force but strongly recommends each participant to wear a neck brace.

D) It will help a doctor or an official staff to avoid giving pressure to an injured participant whose neck can be damaged due to an accident when taking off his/he helmet. Exceptions are acceptable if embedded.

Motorcycle class to wear a neck brace is mandatory for each rider.

- E) Sunglasses, caps or hats
- F) a tent, a sleeping bag (Schlafsack)
- G) 2 red hand-held smoke flares or cyalume light sticks
- H) 2 pocket lamp (one of head-type lamp)
- I) For motorcycle class, capable handy map holder in case shape.
- J) Dining-ware
- K) Medical kit (per one competitor):
 An eye wash, a painkiller, two kinds of binding medicines, an antibiotic, bandage, an adhesive plaster, a lip balm, Vitamin C, tablets of sodium chloride, a disinfectant
- L) Survival kit (per one vehicle):
 Magnetic compass, an aluminum sheet (larger than 2mx1m, one sheet per one person), 3 liters water for one person in desert and 1.5 liters water in the other areas, 2000kcal of emergency rations for one person carried by participants at all times (it is not lunch pack), a pair of tie-down belts *The ratchet -type tie-down belt that fixed cancellation and certain , simple tension adjustment are possible in one-touch. (for the Motorcycle Class), 2 ropes of enough size and length (8m or longer) to tow (for Auto Camion Class)
- M) Communication Equipment:
Satellite telephone (compulsory) We will send about details of satellite telephone.
 Each participant must bring a satellite cell-phone (Iridium Satellite Phone) with him/her to contact in emergency situations.

ART.8 IDENTIFICATION DISPLAYS AND THEIR REQUIRED SPACES

8.1

The participants are required to clear the following spaces for identification of the entry number, ID sticker, and stickers offered by the sponsor:

For Motorcycle Class:

Front light cover and upper side of the right and left side-covers (330mm×150mmr more for each), Surface of the tank (100mm×100mm for each side)

Note: When using parted (saddle-bag style) bags and so on, mount the plastic plates for attaching the race number on both right and left sides.

Note: always attach the side race number on the side cover section at the rear of the vehicle at a position where the rider's body won't block others from viewing the number. Attaching to tanks and shrouds is prohibited.

Auto Camion Class:

Side-doors (2 spaces of 500mm×500mm for each side)

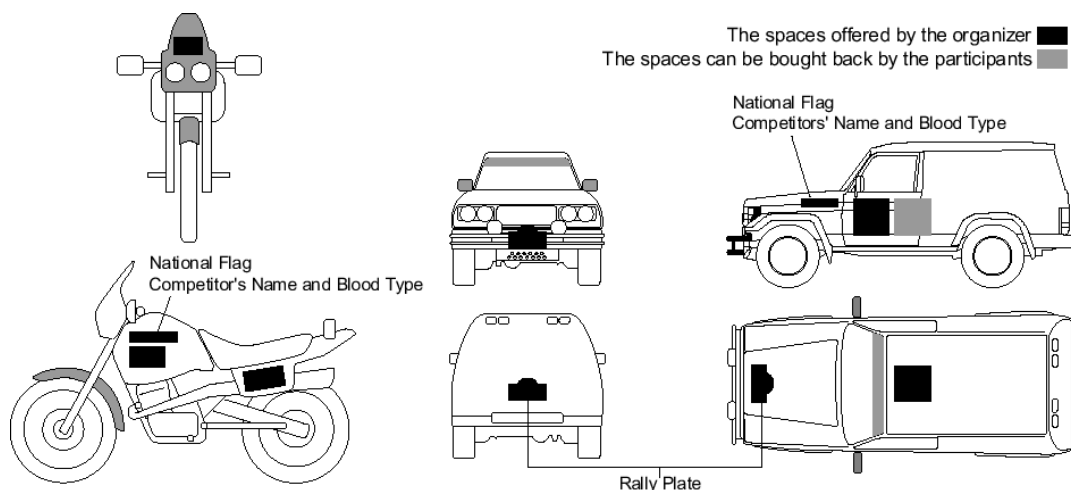

8.2

4 pieces of cloth (25cm×25cm) with an entry number on them will be given to each entrant. This cloth should be attached on both the front and the back of the jacket of a participant in Motorcycle Class. When the backpack is shouldered, it installs it is the side in the back. A preliminary number recommends the sewn thing to the entrusted duffle bag.

8.3 OBLIGATORY DISPLAY OF NATIONAL FLAGS AND COMPETITORS' NAMES

Every competitor shall display the national flag of his/her own country, his/her name and blood type on his/her vehicle and helmet. For Auto Camion Class, this display on the vehicle shall be put on both sides of the front fender tops or front doors; for Motorcycle Class, on both sides of a front cowl or right and left of upper side of a tank.

All displays should be contrastive with the color of a vehicle's body and helmet and also recognizable anytime immediately.

8.4 DISPLAY OF ID SHEET

Participants in Auto Camion Class shall firmly attach onto the body of his/her vehicle its ID sheet given by the organizer at the inspections so that it can be identified clearly by the organizer during the rally.

Those in Auto Camion Class who leave their vehicles and those in Motorcycle class must carry their ID cards on themselves. This is required from Administrative inspection until the end of the closing ceremony.

ART.9 ROUTE BOOK, TRAFFIC REGULATIONS

9.1

All participants will be given a route book, according to the class they're participating in, in which the route of the rally is shown. Participants must obey the regulations mentioned in it. Violation of the rules will result in disqualification.

Route books will be written mainly in Japanese with partial English translation attached. They will measure distances in kilometers to the nearest hundredth of a kilometer (10m). They are A5 (148mm×210mm) in size and bound. All route books will be provided to participants by the time of Comprehensive briefing at Ulaanbaatar Hotel on August 10, 2018.

9.2

All the routes in the rally are right traffic.

9.3

Headlights should always be shining regularly while driving.

9.4 GPS log submission

The organizers will establish a temporary parc ferme for participants to submit their GPS logs when they reach the goal. The top finishers and random other vehicles will be sent into the parc ferme and requested to submit their travel log for the day. It is the responsibility of participants to manage their travel logs. Participants register the GPS they use with the organizers beforehand. Traveling the decided on route is a crucial element of sportsmanship in order to protect the fairness of the competition. In principle, the participants have the responsibility to show the results of their travel.

ART.10 ASSISTANCE

10.1 DEFINITION

Assistance including various aids for competitors to continue racing will be offered by the organizer. However, to provide fair assistance to only those in need, certain restrictions for use of this system will also be enacted. Every participant should act with good will as a fair cross country racer, and must not attempt or practice any unfair assistance.

10.2 DEFINITION OF TEAM

A team must consist of 3 or more competitors and have identity in the graphics of vehicles, sponsors, uniforms and so on. The number of team staffs should never exceed the number of entrant competitors of the team in principle.

10.3 LIMITS OF ASSISTANCE

(Besides the assistance prepared by the organizer) it is permitted to receive assistance from another participant only if necessary. Also, it is possible to receive unplanned assistance from some native residents. All participants must stay in view of the organizer's vehicle located at the center point at all the bivouacs. In addition, it is possible to have technical assistance from the participants who have been registered as mechanics.

It is forbidden receiving the technical support with the mechanic other than the bivouac.

However, any assistance from those who have retired from the rally, such as giving or receiving parts from retired vehicles, is strictly prohibited.

Non-registered vehicles and their users are prohibited from approaching anywhere within a 5 kilometer radius of the tents where the sponsors are camped. Rally participants who violate this rule will be immediately eliminated from participation in the rally.

10.4 ASSISTANCE PREPARED BY THE ORGANIZER

(A) Transport of Tires for Motorcycle Class

Each participant in Motorcycle Class will be provided with free transportation service for up to four tires (including two wheels). Pay attention to any information before starting a new course because course conditions may delay or prevent the arrival of a service camion at a bivouac.

(B) Transport of Duffel bags for Motorcycle Class:

Each participant of Motorcycle Class can put a duffel bag (Maximum volume: 450mm [height] by 400mm [width] by 900mm [length]). Duffel bag weighs maximum 30kg and must be sturdy. Contents of duffel bag should be waterproof. Neither cardboard nor hard cases must not be in the duffel bag. Cardboard boxes and hard cases can't be use as a duffel bag. It is foreseen that the arrival of the "X-1" service truck may be drastically delayed or prevented altogether by weather or various other course conditions. Therefore, it is necessary to pay attention to the information provided beforehand.

(C) Transport of duffel bags and tires for Auto Class (except Camion Class):

Each vehicle in Auto Class will be provided with free transportation service for up two sets of complete tires on rims. Transportation of additional tires will require payment of a transportation fee of 20,000yen per tire.

It is foreseen that the arrival of the "X-1" service truck may be drastically delayed or prevented altogether by weather or various other course conditions. Therefore, it is necessary to pay attention to the information provided beforehand.

Each participant of AUTO Class can put a duffel bag (Maximum volume: 450mm [height] by 400mm [width] by 900mm [length]). Duffel bag weighs maximum 30kg and must be sturdy. Contents of duffel bag should be waterproof. Neither cardboard nor hard cases must not be in the duffel bag. Cardboard boxes and hard cases can't be use as a duffel bag.

(D)A mechanics or a participant of Team Manager Class can put a duffel bag (Maximum volume: 450mm [height] by 400mm [width] by 900mm [length]). Duffel bag weighs maximum 30kg and must be sturdy. Contents of duffel bag should be waterproof. Neither cardboard nor hard cases must not be in the duffel bags. Participants will load Camion with their duffel bags by themselves.

The person registered as an assistant can bring his/her baggage (Maximum 10kg) in the helicopter or the four-by-four. He/she must have it with him/her all the time and load a helicopter or a four-by-four his/her baggage by himself/herself.

(E) Equipment in Service Camion

Compressor, welding machine, tools will be able to use by competitors.

10.5 AIR ASSISTANCE

The organizer will permit registration of a team manager from each officially entered team or a mechanic who can move by helicopter. However, carrying parts on a helicopter is not permitted. The luggage loaded onto a helicopter should be less than 10kg per person, and the excess (in a duffel bag, less than 30kg) will be kept in a service truck (camion).

All applications shall be accepted in the order they are received and closed as soon as the racing list is full.

A team manager, on behalf of his/her team, is entitled to protest or question the organizer officially. The team manager is not permitted to carry out any publicity activities, including interviewing other participants.

10.6 ASSISTANCE OFFERED BY THE ORGANIZER OFFICIALS

Organizer officials are not permitted to offer any assistance to a competitor or a racing vehicle at places other than specified in ART 10.4 and for emergency. Officials and press-people may offer assistance to retired competitors or retired vehicles after their notice of retirement from the rally received.

10.7 UNFAIR ASSISTANCE

It is strictly prohibited for a vehicle, a motorcycle, a helicopter to lead, accompany, or chase a racing vehicle or take another route before or during the rally.

The above-mentioned act shall be considered as unfair assistance.

This prohibition shall also be applied to the unfair assistance by a retired vehicle or a retired competitor.

ART. 11 MEDICAL SYSTEM

11.1 MEDICAL EQUIPMENT AND SYSTEM

The following medical system shall be prepared by the organizer:

1) Medical Car.....1unit (One doctor equipped with medical kits will cover from the starting point of each etap through the middle till the end.)

2) Helicopter.....1unit (One or two doctors equipped with monitoring instruments will stand by.)

11.2 EMERGENCY TRANSPORTATION

The organizer will be prepared in case participants might have an unexpected accident and need to be transported to a well-equipped medical institution. If such a misfortune happens, the patient shall be transported on an emergency basis to the nearest hospital.

The emergency medical team consists of two Japanese doctors and two Mongolian doctors. The team consists of 1 physician, 1 surgeon, 1 brain surgeon and 1 anesthetist.

The number of this medical team doctors may be changed depending on the number of participants in the rally. In case the injured does not need serious treatment in a hospital, he/she will be transported to the head office of the rally or the office in Ulaanbaatar. The liability for emergency transportation borne by the organizer shall be limited to transportation to a hospital in Ulaanbaatar that has been contracted with the organizer.

11.3 MEDICAL CHECK AND INSPECTIONS

(A) Medical inspections will be held by the organizer during Administrative Inspections. All competitors must have these check ups and obtain professional approval from the chief doctor to participate in the rally.

(B) If participants in any etap goals later than the midnight (0:00a.m.), they shall report to the medical section for a check up and obtain professional approval from the chief doctor to continue the rally before their own starts of the next etap.

(C) A participant will receive a medical examination whenever the chief of competition or chief doctor finds it necessary.

ART.12 CHECK CARD

12.1

At the start of every morning, participants will be given a check card on which the starting time is recorded. This card is 148mm×210mm (A5 size) and made from resinous paper.

Participants have the responsibility of keeping it in good enough condition that it is possible to read the record.

12.2

Any amendment or change to the check card will result in disqualification.

12.3

Participants should show their check cards at every Time Control and Passage Control. Check cards will be collected everyday at the last Time Control of each etap.

12.4

Participants should have their check cards stamped or recorded at all the Time Controls and Passage Controls mentioned on the cards.

Failure to stamp or record on check cards will result in participant penalties.

12.5

If a participant loses the check card, he/she will receive a penalty of 30 minutes or more.

ART.13 CONTROL ZONE

The beginning and the end of every control zone is marked by flags.

13.1

Yellow flags mark the beginning of a control zone and are located 100 meters before the checkpoint. Red flags mark the checkpoint. The end of the checkpoint, which is located 100 meters after the checkpoint, is marked by a beige flag with three black lines.

Control zone refers to an area of 100m + 100m as a rule. But it may be shortened to minimum 20 meters depending on the type of control or the geographical conditions.

13.2

It is strictly prohibited to enter the control zones from the directions which are not mentioned in the route book. Once a participant enters a control zone and has his/her card recorded, the participant is not allowed to enter the control zone again, from any direction.

The first violation of this rule will result in a one-hour penalty, and the second one will lead to disqualification.

13.3

The control zone is ruled completely by the officials. In this area, nobody can perform maintenance on a vehicle except for cleaning or wiping the entry number, the sponsor stickers and lights. Also, to take a rest in this area is not allowed.

Violation will result in participant penalties, if it happens more than several times, the participant will be disqualified.

13.4

In a control zone, competitors must slow down. Passing other vehicles is strictly prohibited. Also, no one can receive assistance in any control zone. Vehicles must be driven only by the impelling force generated by their engines, not pushed, pulled, or towed etc.

ART.14 TIME CONTROL

14.1

Competitors must hand in the check card when they cross over the line shown by the red flag at the time control at the beginning of the special. The time planned to start the special is recorded here. Competitors must go to the starting position flag mark of the special stage right after the check.

Between these two checks they will be given five minutes to prepare for the start. When a tire is flat, they will be given twenty minutes maximum. But they will receive a penalty if it takes more than twenty minutes.

14.2

Maximum permitted time, at most, is a continuous sixteen hours. The maximum time for each etap is determined and released beforehand.

ART.15 PASSAGE CONTROL

15.1

Passage control is prepared to make sure that competitors take the proper route mentioned in the route book, or to check the position within the etap.

The exact position of the passage control will be released before the start of etap. Failure to pass the passage control will result in the following penalties.

- 1st time 1 hour
- 2nd time 2 hours
- 3rd time 4 hours
- 4th time and thereafter 6 hours

The number of passage controls will be changed depending on the conditions of etap. If some part of a special has to be canceled for one reason or another, the officials will practice a special time check so as not to let the whole SPECIAL be affected.

15.2

In a loop-designed route that the goal bivouac is the same point as that of the starting, if a competitor fails to pass a passage control of the etap, he/she will receive one of those penalties mentioned in Art.16.2 and additional 1 hours or the latest time record of the etap.

ART.16 ETAP(SPECIAL and LIAISON)

16.1 SPECIAL

The designated time for a start at the special stage and liaison must be strictly observed. A delay of less than 60 minutes will result in a penalty, and that of 60 minutes or more will result in disqualification.

When a competitor uses a different route from the special stage, he/she will be disqualified from the rally or given the equivalent penalty.

A break away at the start will result in a one-minute penalty, and violation in the starting order will result in a five-minute penalty. *The engine must be working at the end of the special. (Vehicles must be driven through, not pushed, pulled or towed etc.)*

Time Control will be practiced at the finish of the special.

See the last page of this regulation

- A) Yellow flag : the beginning of the zone
- B) Red flag : 100 meters from the beginning (checkpoint)
- C) Second red flag : 100 meters from B (stop)
- D) Beige flag with three black lines: 100 meters from C (the end of the zone)

Competitors must not stop between the yellow flag (A and the second flag C). They must stop between the second flag (C and the last flag D). At this point, the time is recorded on the check card by an official (hours, minutes & seconds). If there is another liaison after that, the finishing time will be the starting time of the liaison.

16.2 TIME CHECK AT THE SPECIAL

In the Special, the time will be checked in hours, minutes, and seconds. Each time control will be read in seconds and figures less than seconds will be omitted.

16.3 LIAISON

In this section, vehicles must run in the designated time (time allowed) based on the speed limit of the traffic. In this area, a one-minute delay will mean a one-minute penalty.

The penalties for the Maximum Permitted Time are also added to this penalty when a competitor is late.

16.4 TIME CHECK AT LIAISON

In this section, time will be checked in hours and minutes. Each time control will be read in both hours and minutes, and figures less than minutes will be omitted.

ART.17 BRIEFINGS

A) *A briefing will be held by the chief of competition everyday, in the presence of the judges, in front of the official's tent (Head Office) at least 1 hour before the first vehicle's starting of a day's etap. All participants in Motorcycle Class and at least one driver of every vehicle in Auto Camion Class shall attend these briefings.*

B) Participants who ignore a briefing can never protest against the disadvantage of it.

C) In addition to the regular briefings explained above, the organizer (the chief of competition) will hold special briefings anytime needed. The time and date of the temporary briefing will appear on the bulletin board of Head Office.

ART.18 RE-GROUPING

Competitors in an etap will be gathered and checked Time Control, then move through the etap by convoy for security reason when the race is impossible to be continued due to a sandstorm or the sudden change of the course.

ART.19 STARTING

19.1

All the starting shall be made in the control zones. (See Art.13)

19.2

The first vehicle in each etap of the day shall be recorded on an official timing chart. When official timing chart will be changed by organizer, it shall be presented by 0:00a.m. at the bivouac.

19.3

The organizer shall control all of the starting. Crossing the start lines without permission or the starting signals from the organizer is strictly prohibited. All vehicles shall be capable of starting up only by the power of the engine and not receive any assistance from anyone.

The grand start in Ulaanbaatar will be in order of entry number. The starts of other stages will be according to instructions from the organizers or according to the general ranking of the previous day.

19.4

A participant who is going to start from an etap must goal the etap which should been finished by two days before in his/her schedule, and must finish submitting his/her check card by 30 minutes before the starting of the first vehicle in his/her class. Failure to complete the goal or to submit the check card will result in disqualification.

19.5

If the goal and checker card presentation has not been completed in continuous etaps, it shall result in disqualification.

ART.20 PLACINGS

Total placing depends on the time record of the special stage and penalties. The competitor who has the fastest time record is ranked first. If competitors have the same time records, the placing will be decided by the time record of the first day's special stage. If these records are also the same, the second day's time record will be compared. If it is still impossible to rank them, the third day's time record will be compared.

Provisional placing will be noticed by 0:00 a.m. at the bivouac.

ART.21 PROTESTS

Protests must follow the international sport regulations. Any participant who makes a protest must submit a paper, which is clearly written the details with time and date, with US\$100 for Motorcycle Class and with US\$300 for Auto Camion Class as a protest charge.

The defendant competitor should have the inspection performed by the committee. Regarding the other protests without any protest charge, the committee will be sent or reported orally. The cost of the protest is non-refundable in any case unless the protest is reasonable and accepted by the committee.

ART.22 SAFETY

22.1

A competitor, who retires from the rally in the middle of the race, must inform the organizer by using satellite telephone by the end of the etap on the day.

If a competitor retires from the race without reporting it to the organizer, it may result in a special search for him/her since the organizer does not know where he/she is. In this case, he/she will be responsible for all the costs required for the search.

If a competitor retires from the rally, he/she will not be transported by the organizer's airplane at any place on the route and he/she must go to Ulaanbaatar.

22.2 ROUTE CLOSE

The route will be closed as the organizer vehicle (Camion) brings up the rear after the last competitor. No competitor shall remain on the route once it is closed by Camion.

In the Motorcycle Class, a rider who meets the Camion will be retired in certain time and must get in the Camion with his/her vehicle to be transferred to the bivouac of the day. There will not be any other chance for him/her to have a vehicle picked up by the organizer.

As well, in the Auto Camion Class, a driver who meets the Camion will be retired in certain time, the driver and co-driver must get in the Camion to be transferred to the bivouac of the day. In this case, the organizer will make all possible attempts to pick up their vehicle. However, the organizer will bear no responsibility or liability for their vehicle even through its transfer is not possible for some unfortunate reason.

In all Classes, competitors who refuse to get in the Camion must sign the recognizance on the back of the check card.

Any participants who do not follow this instruction shall lose all of the rights of this rally.

The organizer shall not be responsible for any consequences that may happen as a result of non-compliance with this instruction.

ART.23 RESPONSIBILITY FOR HELPING OTHERS

If a participant find the injured who needs help, he/she and the following participants must stop and inform the other participants and the organizer as soon as possible.

However, in the case that he/she is delayed because of this reason, the delaying time will not be deducted from his/her time record. All competitors should do their best to avoid such a serious accident.

ART.24 PICTURE COVERAGE

The organizer has the express authority to publicize or broadcast this event by TV, radio, movies or photos, using participants' name or photos for the sake of publicity.

Anyone who wants to use the trademark or picture coverage of this rally must request permission and make a contract with the SSER ORGANISATION.

ART.25 RESOLUTION OF CONFLICTS

25.1

All lawsuits regarding this event shall be brought to the Japanese court which is located in the same region as the organizer.

25.2

Items other than those specified in this regulation shall conform to the Japanese laws and ordinances.

ART.26 ENVIRONMENT

Any and all kinds of trash dumping or littering by participants and sponsors during the rally is absolutely prohibited. Trash from your lunch-pack must be brought back to the bivouac and later exchanged for the next day's lunch-pack. Rally competitor's race numbers are attached to the water pet bottles we distribute so those who carelessly throw them away somewhere will have to pay a fixed penalty. Dumping trash carries a penalty of 200 US dollars the first time, and rally disqualification the second time. If you have waste oil from oil changes and so on then dispose of the used cans at the recycle oil drum at the rally headquarters. Those who do not observe these essential rules will be disqualified. No exceptions or protests to this case will be accepted.

Please note: The original Japanese regulation has priority over the regulation translated in English even though there might be some differences between these regulations.

ART.27 PENALTIES

DETAILS FOR PENALTY	ARTICLE NO.	DELAYED START (MAX.60 MIN) Disqualified for over 60 min	TIME PENALTY OR FINE	DISQUALI- FICATION
False Record of a participant's ID/Illegal Switch of a competitor	ART.3.1	x
Unauthorized participants, assistance from unauthorized participants, approaching near the camp (bivouac) area	ART.10.3	x
Refusal to Answer Inspector's Question or Present Vehicle	ART.7.2	x
No Medical kit Loaded	ART.7.4	x		
No Water Loaded	ART.7.4	x		
No Obligatory Safety Equipment Loaded	ART.7.4	x		
Refusal or Failure to Carry Obligatory Ad. or Plate THE FIRST TIME THE SECOND TIME	ART.8	Half of Entry Fee	 x
Intentional Failure to Put Number Cloth on Chest or Vehicle THE FIRST TIME THE SECOND TIME	ART.8	10% of Entry Fee	 x
Passage of Wrong Route, or route which is not listed in the Route Book	ART.9.1	3 hr.	x
Head Light Fails to Light at the Start	ART.9.3	x		
Parts Transport or Assistance by Non-Participant or the Disqualified	ART.10.3	x
Assistance by Non-Participant at the Bivouac	ART.10.3	2 hr.	x
Unsportsmanlike Behavior	See FIA/FIM Sports Code	x
Fabrication of Check Card	ART.12.2	x
Loss of Check Card	ART.12.5	30 min.	
Entering Control Zone from the Wrong Direction THE FIRST TIME THE SECOND TIME	ART.13.2		1 hr.	 x
Entering the Same Control Zone Twice THE FIRST TIME THE SECOND TIME	ART.13.2	1 hr. 2 hr.	
Act of Disobedience to Officials' Instruction within the Control Zone	ART.13.3	2 hr	
Failure to obey Traffic Rules such as Passing or Speeding Limits within the Control Zone	ART.13.6	1 hr.	
Entering the Time Control with the Engine killed (e.g. hauling, pushing etc.)	ART.13.6	x
Engine Fails to Work at the Start	ART.13.6 ART.19.3	x x		
Failure to Pass Passage Control THE FIRST TIME (*refer ART.15.1. According to conditions) THE SECOND TIME THE THIRD TIME THE FOURTH TIME	ART.15.1	1 hr. 2 hr. 4 hr. 6 hr.	
Failure to Pass Passage Control (loop-designed route)	ART.15.2		+ 1 hr.	
Delay in special and liaison designated start times	ART.16.1	x	1min. Penalty for each 1 min. delay	
False start (flying)	ART.16.1		1 min	
Disobedience in the Placing at the Start	ART.16.1	5 min.	
Late for Liaisons	ART.16.3	1min. Penalty for each 1 min. delay	
Not reaching the goal for the stage two stages before the current stage and completing the presentation of the check card by 30 minutes before the No.1vehicle in the department starts the current stage	ART.19.4	x

Control Flag Information

Time Control followed by a start of a special スペシャルのスタート地点のコントロールゾーンにおけるフラッグ

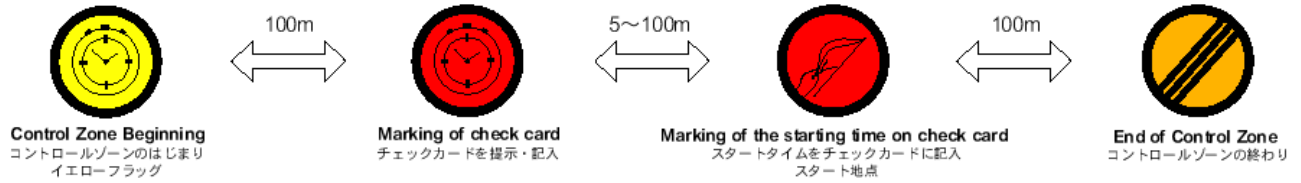

Arrival of a special スペシャルのゴール地点のコントロールゾーンにおけるフラッグ

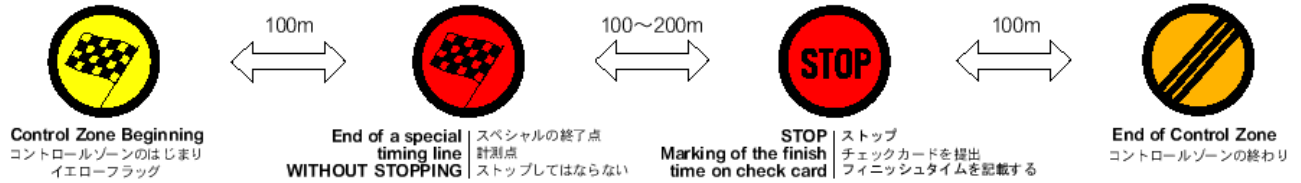

Passage Control パッセージコントロールのコントロールゾーンにおけるフラッグ



TECHNICAL REGULATIONS For AUTOMOBILES

Technical regulations for the AUTO CLASS are not listed here since they are identical to FIA Technical Regulations. However, the SSER has some relaxed some vehicle inspection criteria. Major points each participant must be aware of are that vehicles registered in this class require at least a six-point roll cage of seamless steel, with a bend curvature of no less than a 100 degrees, and sufficiently reinforced for safety; as well as 4-point seat belts securely attached to each seat with eyebolts. Any projections pointing towards those in the vehicle must be completely removed or adequate protection provided. The mounting of automatic fire extinguishers and circuit breakers may be omitted. Please refer to FIA technical regulations for mounting fenders on vehicle types where the tires are exposed from the body. Each vehicle must also have two spare tires mounted on rims. Auxiliary containers for carrying fuel are only allowed to consist of safety tanks or traditional metal gas containers. Their mounting methods and clamping methods shall be secure and reliable. Vehicles equipped with a fuel tank not specified by the vehicle manufacturer must also have a manual type AFFF 2.4 liter or FX G-TEC, Viro3, powder 2.0 kilogram fire extinguisher. Vehicles equipped with a safety tank must basically also be equipped with (Earls) Aero-Quip Type fuel hose type clamps. If using hose clamps is unavoidable, then 2 hose bands (or hose clamps) must always be mounted on each coupling section having metal sheathing . The fuel pipes must also be clamped so as not to come in contact with other objects during driving. Any batteries kept within the vehicle must be clearly separated from the fuel pipe and suspension reservoir tank. These must be separated by a metal divider or partition.

TECHNICAL REGULATIONS For MOTORCYCLES

ART.1 DEFINITION OF ELIGIBLE MOTORCYCLES

1.1

Motorcycles in this rally must come under Group1.2.3 provided especially by this rally based on Technical Rules of FIM. The technical regulation of this rally must be obeyed.

Group1: Production

Rear wheel drive 2 wheeler motorcycles on the mass product, unmodified

Group2: Super Production

Rear wheel drive 2 wheeler motorcycles on the mass product, modified.

Group3: Experimental

Motorcycles produced experimentally, the Quad, ATV or sidecars following ART1.2.

1.2

The acceptable motorcycles in this rally must be registered in each of their countries, or prepared with the deletion of the registration or the registration, and be able to prepare the documents of a transfer or import. Motorcycles in Group3 must also fill the same condition.

ART.2 HOMOLOGATION

2.1

Motorcycles in Group1 are usually required the homologation except those filling the following conditions.

Motorcycles must be produced more than 200 a year, sold by the manufacturers for everyday road use, the commercial catalogue production models. It means that motorcycles on these kinds of extant and submissive manufacturers' catalogues are not required homologation.

2.2

The participation of motorcycles in Group2 or 3 do not depend on the number of the production and their catalogues are not required. Notes: it is not necessary for Motorcycles in Group2 to submit catalogues only in this rally.

ART.3 DEFINITION OF A FRAME

Frame - The structure or structures used to join any steering and/or suspension mechanism at the front of the machine to all the components of the rear suspension and to support the engine/gear box unit. (see diagram 1)

ART.4 GENERAL SPECIFICATION

Participated motorcycles in every class must comply with the specifications below (see diagram 2).

4.1 STARTING DEVICES

Motorcycles must be equipped with starting devices functioning normally.

4.2 OPEN TRANSMISSION GUARDS

Motorcycles must be equipped with counter shaft sprocket covers.

4.3 EXHOUST PIPES

Exhaust pipes and silencers must fulfill all the equipments concerning sound control. The exhaust must discharge from the end of the exhaust systems.

4.3.1

The end of the exhaust pipe must be horizontal and parallel (over a minimum distance of 30 mm) to the central axis of the solo motorcycle (with a tolerance of $\pm 10^\circ$).

4.3.2

A part of frames must not be as a part of exhaust pipes.

4.3.3

The extremity of the exhaust pipes for solo motorcycles must not pass the vertical tangent of the rear tire.

4.4 HANDLEBARS

4.4.1

The length of handlebars is: not less than 600mm and not more than 850mm.

4.4.2

Exposed handlebar ends must be plugged with a solid material except metals or rubber covered.

4.4.3

Stoppers, (other than steering dampers) must be fitted to ensure a minimum clearance of 30 mm between the handlebar with levers and the tank when on full lock to prevent trapping the rider's fingers.

4.4.4

Handlebar clamps must be very carefully rounded and engineered so as to avoid fracture points in the bar.

4.4.5

If hand protectors are used, they must be of a shatter-resistant material and have a permanent opening for the hand.

4.4.6

The repair by welding of light alloy handlebars is prohibited.

4.4.7

The length of handle grips must be less than 150mm and installed at the edge of handles.

4.5 CONTROL LEVERS

4.5.1

All handlebar levers (clutch, brake, etc.) must be in principle ball ended (diameter of this ball to be at least 16mm). This ball can also be flattened, but in any case the edges must be rounded (minimum thickness of this flattened part 14mm). These ends must be permanently fixed and form an integral part of the lever.

4.5.2

Each control lever (hand and foot levers) must be mounted on an independent pivot.

4.5.3

The brake lever if pivoted on the footrest axis must work under all circumstances, such as the footrest being or deformed.

4.5.4

The distance between points of a pivot and the edge of a lever (or a ball) must be less than 200mm.

4.6 THROTTLE CONTROLS

Throttle controls must be self-closing when released by hand.

4.7 FOOTREST

4.7.1

Footrests may be of a folding type but in this case must be fitted with a device that automatically returns them to the normal position, and an integral protection is to be provided at the end of the footrest that must have at least 8mm radius.

4.7.2

If the footrests are not of the folding type or rubber covered, they must be rounded with a spherical radius of not less than 8mm.

4.8 BRAKES

Motorcycles must have brakes operated independently and concentrically with the wheel.

4.9 MUDGUARDS

Motorcycles must be fitted with mudguards.

4.9.1

Mudguards must project laterally beyond the tire on each side.

4.9.2

The front mudguard must cover at least 100 degrees Centigrade of the circumference of the wheel. The angles, which formed by one line drawn from the front edge of the front or rear mudguard to the center of the closer wheel to each mudguard and another drawn horizontally through the center of the wheel, must be between 45 ° and 60 ° for the front mudguard, within 20 ° for the rear mudguard.

4.9.3

The rear mudguard must cover at least 120 degrees Centigrade of the circumference of the wheel.

4.10 ENGINE

The engine must function on normal fuel and be of a type equivalent to fuel from public fuel stations.

4.11 LIGHTING AND WARNING EQUIPMENT

4.11.1

Motorcycles must be equipped with a front light and rear lamp that can be turned on anytime while riding.

Equip the rear with a reflector.

4.11.2

The rear lamp must illuminate 5 times as bright as normal when the brake is working.

4.11.3

Motorcycle must be equipped at least one horn

4.11.4

The kill switch to stop the engine must be installed on the handle bar.

4.11.5

Attach a rearview mirror.

(It is desirable to be attached to both right and left. Be attached to the left side at least.)

4.12 TIERS

The acceptable types of tiers are shown the below:

The front tiers dimensions are free.

The rear tiers including ENDURO TIRES must comply with the standard of FIM.

4.13 NAVIGATION DEVICE EQUIPMENT

Motorcycles are prohibited to equip with any navigation devices. Especially, a map holder must not be put on the bridge of the handle bar but at higher position as possible, because it can limit the movement of riders' view. A handle bar bridge is strongly recommended to be equipped with handle bar pads.

And also, a navigation device is prohibited to be installed on the top of a gas tank. Any navigation device, which could be dangerous in case of a tumble, is prohibited to be installed.

ART.5 Group1 PRODUCTION CLASS

Motorcycles in Group1 Production Class must be the same models as the original when they are delivered from the manufacturers. And they must be the same as the contents of their catalogue. These catalogues must be submitted to a technical inspector at a technical inspection. Only one engine marked or sealed must be used for the entire competition. The requirement for normal maintenance, exchange or repair of parts damaged by wear or as a result of an accident, any other maintenances, modifications except its acceptable in Art.5.2 or changes are not allowed.

5.1 Group1 PROHIBITED MODIFICATIONS in Production Class

(Any exchanges are prohibited during the competition)

- A) Engines (including carburetors, alternators, starters, and ignitions) which are not homologated will be marked or sealed.
- B) Reinforcement or changes of frames, Change of materials
- C) Change of the electrical systems or the position of batteries.
- D) Cowlings which are different from the design in a homologation.
- E) Change of braking systems except it is allowed in Art.5.2
- F) Change of types of wheels (spokes, casts, etc.) and hubs
- G) Change of the pitch of teeth of a driver sprocket or the pitch of chain links
- H) Carburetors
- I) The position and material of front forks, rear swing arms and linkage systems, pivots

- J) The position of the air cleaner box must stay originally.
- K) Parts of engines, front forks and frames must be strictly the authentic originals of manufacturer products. Exchanges of above are strictly prohibited during the competition.

5.2 Group1 ACCEPTABLE MODIFICATIONS in Production Class

- A) Change of fuel tanks, Installation of spare tanks on the behind of the seats, Reinforcement of the end of frames in addition.
Reinforcement of frames: to tighten bolts in the end of frames (see diagram 1).
- B) Change of fuel pumps and fuel pipes. Fuel pipes must be fully prepared for preventing the damage by friction.
- C) Secondary Transmission
Change of pinions, ring gears, the number of teeth of a sprocket and the width of chains
- D) Change of the exhausts and silencers
- E) Change of handlebars, grips, control levers and cables
- F) Change of springs of a front suspension and damping oil
- G) Change of rear suspensions
- H) Wheel rims, spokes, hubs only in case of the purpose to change to thick spokes
- I) Change of meters. Speed meters and map holders must be equipped. Wiring to supply the electricity for navigation items is acceptable.
- J) Tubes and tires
- K) Mudguards
- L) Seats, careers, engine guards, break guards, fork protectors
- M) Brake pads, brake linings, brake horses, brake fluids
- N) Air cleaner elements are changeable.
- O) Change of jets of carburetor, slot valves, needles
- P) All of screws, bolts, nuts
- Q) Any material of cowlings

5.3 WEIGHT OF PRODUCTION CLASS

The minimum weight must be equal to the weight of a catalogue data.

ART.6 Group2 SUPER PRODUCTION CLASS

Only one engine marked or sealed must be used for the entire competition. The requirement for normal maintenance, exchange or repair of parts damaged by wear or as a result of an accident, any other maintenances, modifications except its acceptable in Art.6.2 or changes are not allowed.

6.1 Group2 PROHIBITED MODIFICATIONS in Super Production Class (Any exchanges are prohibited in the competition)

Engine (crankcase, cylinder and cylinder head) must be homologated, marked or sealed.

6.2 Group2 ACCEPTABLE MODIFICATIONS in Super Production Class

The following items in Super Production Class are acceptable in addition to the modification and change in ART5.2.

- A) Reinforcement of frames
- B) Change of hubs
- C) Braking system, Quantity of disks and calipers
- D) Change of Carburetors
- E) Change of Ignition system
- F) Change of Clutch, Gearbox
- G) Change of Crankshaft, Piston Assembly
- H) Change of Electric system
- I) Change of Cowling

6.3 WEIGHT OF SUPER PRODUCTION CLASS

The weight is unrestricted

ART.7 Group3 EXPERIMENTAL CLASS

Experimental Class is over the limit of ART.6 SUPER PRODUCTION CLASS. It must satisfy all items of ART.4. Vehicles in this class must be modified for road use whether registered or not. The weight is unrestricted.

ART.8 NOISE CONTROL

The exhausting noise of all motorcycles must be measured in the technical inspection. Changing of Silencers after the measurement is prohibited.

8.1

The position of the microphone for measuring is placed at 50 cm from the exhaust pipe at an angle of 45 degrees measured from the centerline of the exhaust end and at the same height with the exhaust pipe, but at least 20 cm above the ground. If this is not possible, the measurement can be taken at 45 degrees upwards.

8.2 NOISE LIMITS

The noise must be up to 99dB/A under the engine speed 5000r.p.m. or 75% of the engine speed with maximum power.

Diagram-1

1

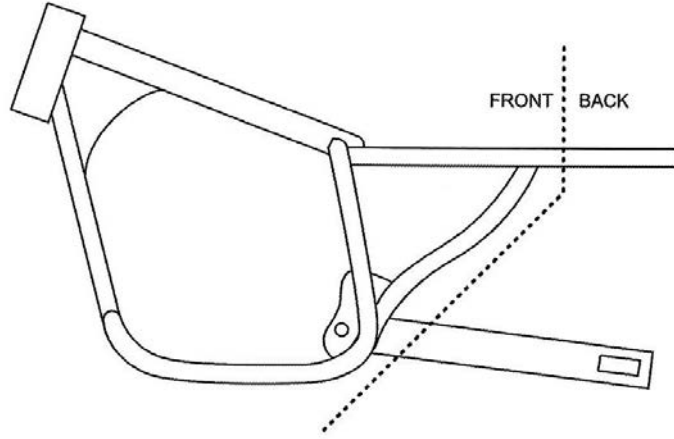

ENDURO / SIDECAR

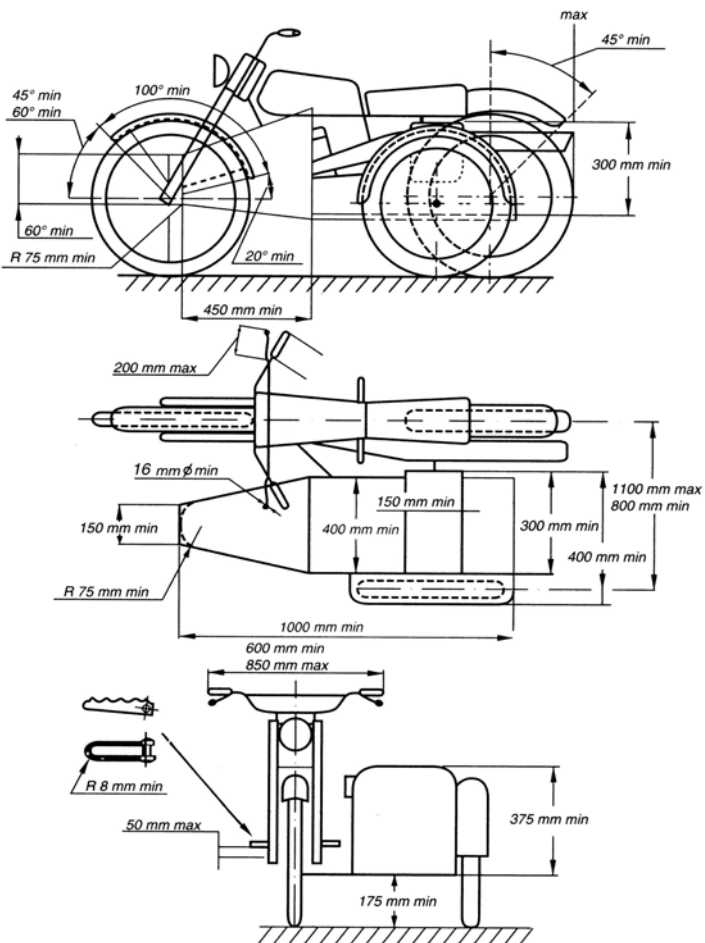

DIAGRAMME Q. QUAD RACER

